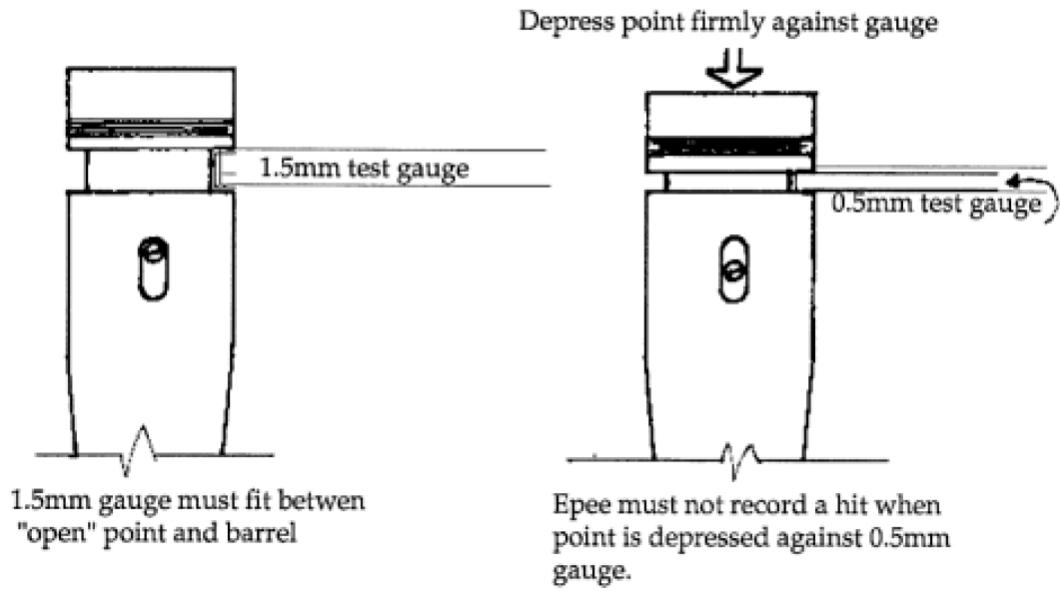
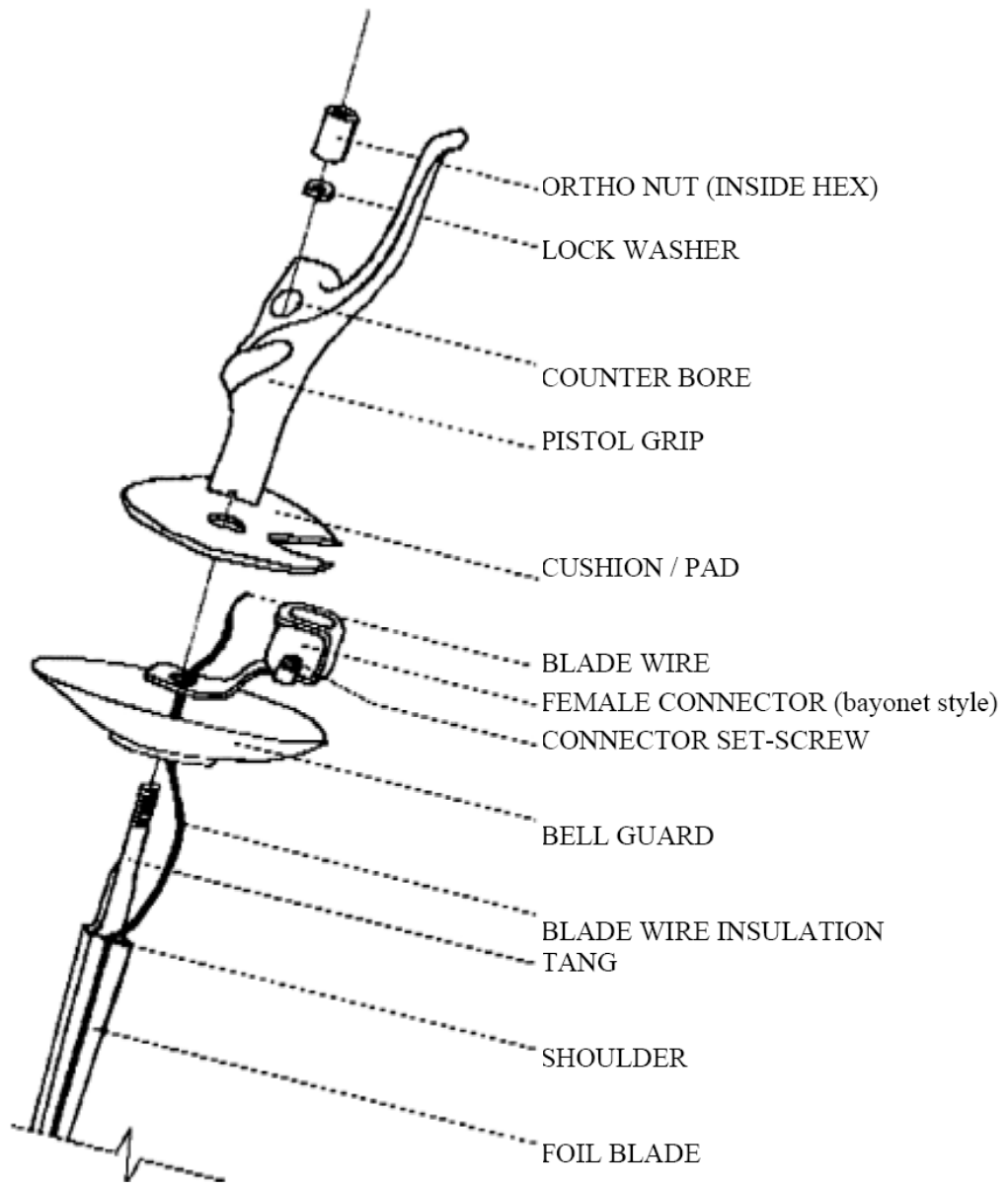

FIG. 3 TESTING THE EPEE POINT FOR 0.5-1.5 mm TRAVEL





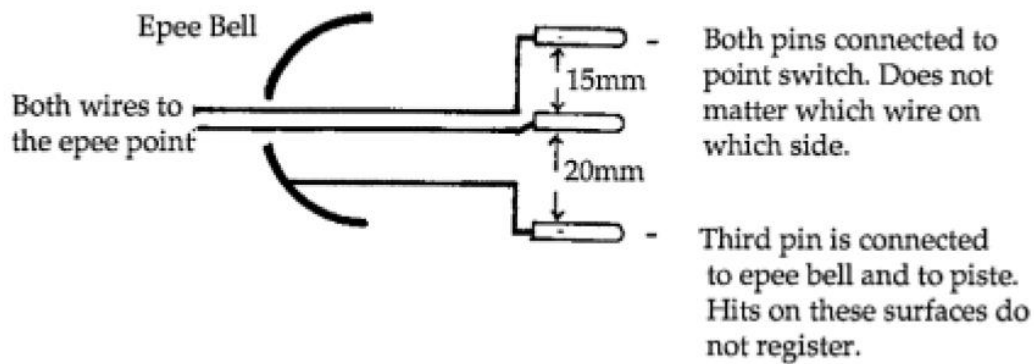

FIG. 9 EPEE SCORING AND GROUND CIRCUITS

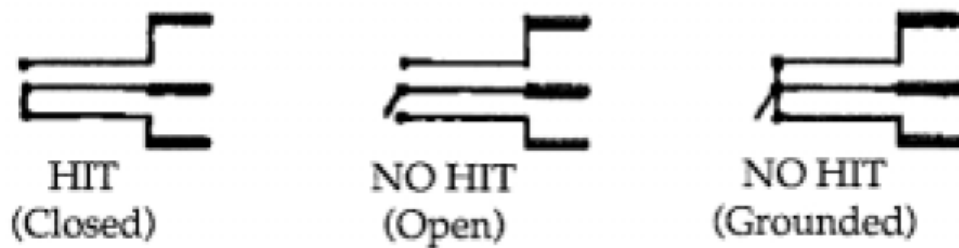
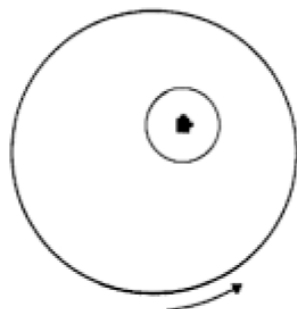

Fig. 10 EPEE HIT REGISTRATION (SCHEMATIC)

EPEE BELL GUARDS (HEAD-ON VIEW)



RIGHT-HANDED FENCER

Showing rotation for left-handed fencer

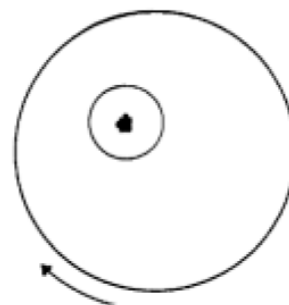

LEFT-HANDED FENCER

Showing rotation for right-handed fencer

## I.E. Viewed from the point